

NOTE: ALL DIMENSIONS ARE IN INCHES.

MATERIALS OF CONSTRUCTION:

- BASE ELBOW: CAST DUCTILE IRON
- LIFT-OUT FLANGE: CAST DUCTILE IRON
- LOWER GUIDE BRACKET: 304 SST
- ALL FASTENERS ARE 304 SERIES SST
- USEABLE GUIDE RAIL SIZES: $\frac{3}{4}$ ", 1", $1\frac{1}{4}$ "
- SPHERICAL SOLIDS SIZE: 3" Diameter.
- MAXIMUM WEIGHT ALLOWANCE: 450lbs.

BERS-0300H-F

PAGE
1

MOUNTING DIMENSIONS

SECTION B-B

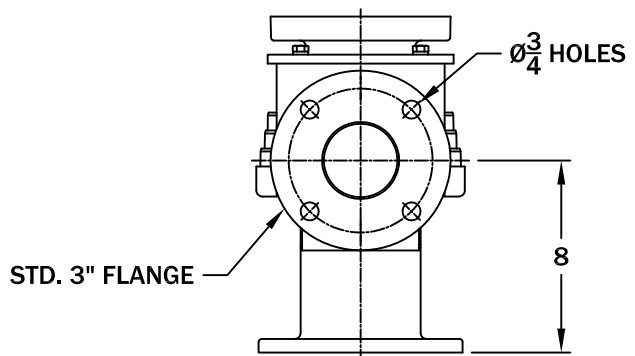
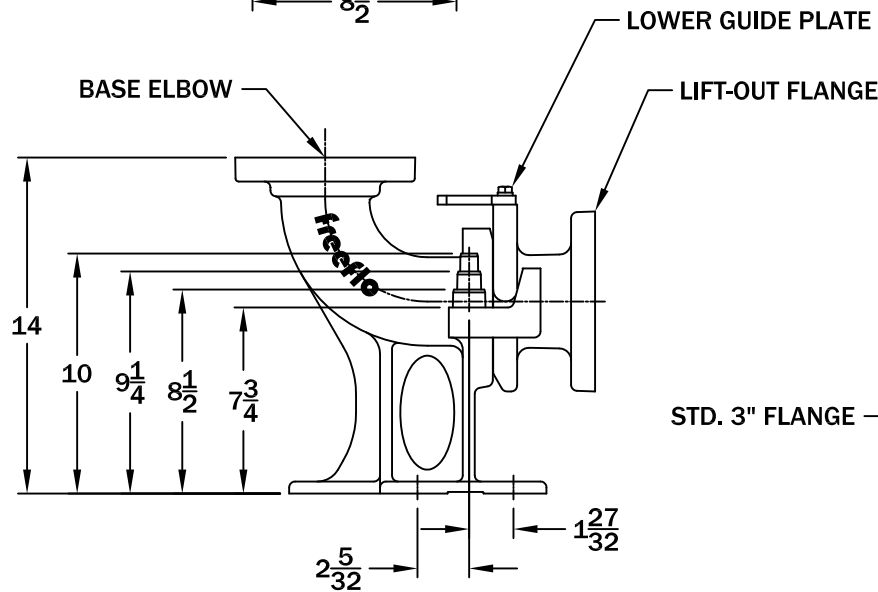
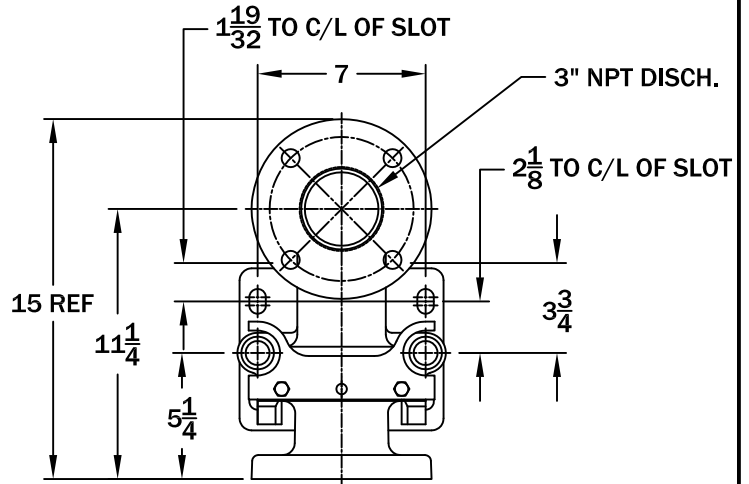
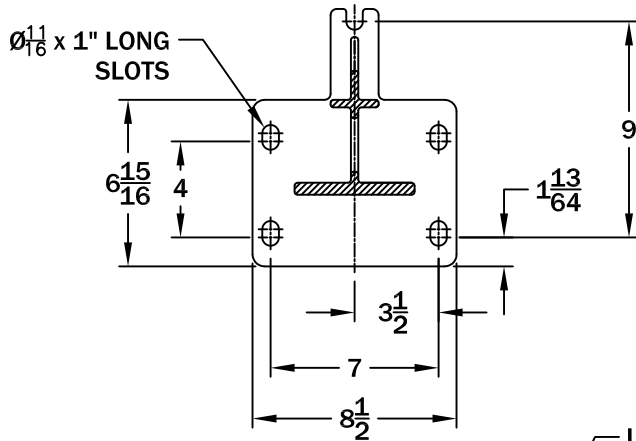

ALL INFORMATION CONTAINED IN THIS DRAWING IS CONFIDENTIAL AND PROPRIETARY TO CONERY MFG, INC.



CHANGES	TOLERANCES	DRAWN BY	DATE
F	DECIMALS	D. MIDDLETON	05/01/20
E	.XXX = ±.005	MATERIAL SPECIFICATION: AS NOTED	
D	.XX = ±.010		
C	FRACTIONAL		
B	X/X = ±.1/64		
A	ANGLES X° = ±1/2°		

SPECIFICATION SHEET
DIMENSIONAL DATA

SCALE:	PART NO.
1/8	3" LIFT OUT DIM