

CAUTION: HANDLE WITH CARE. DO NOT DROP OR IMPACT

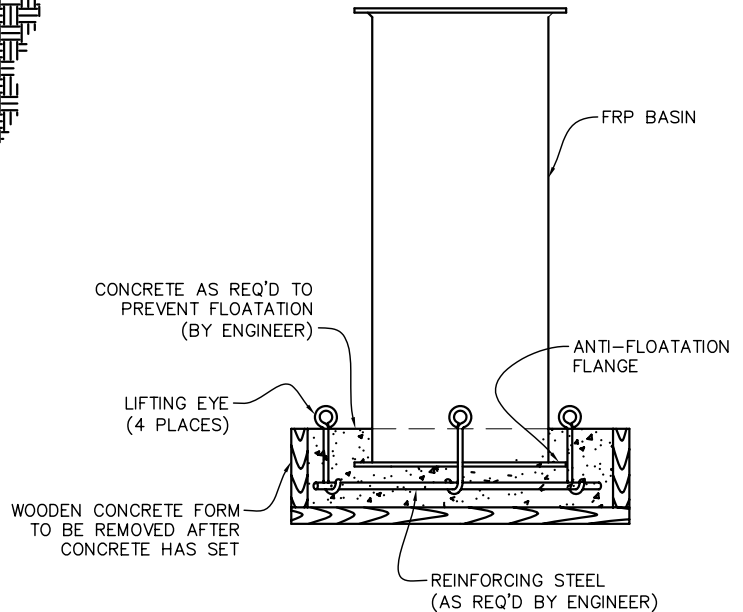
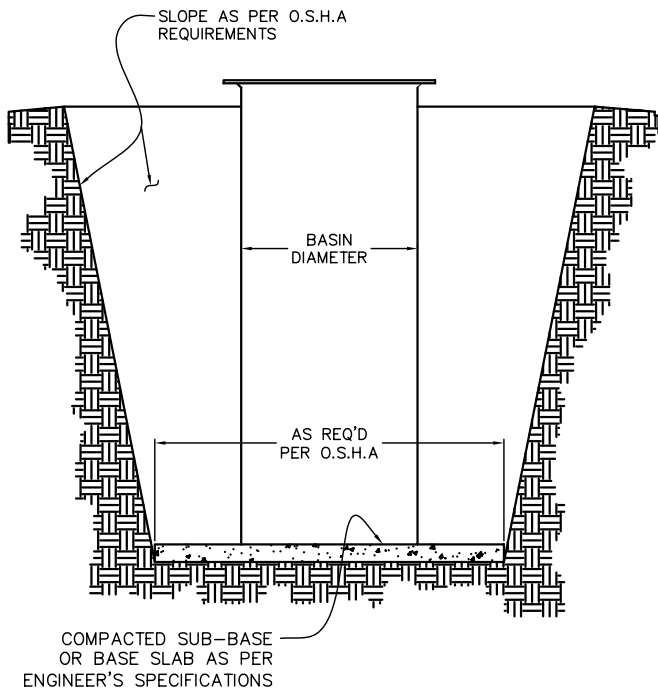
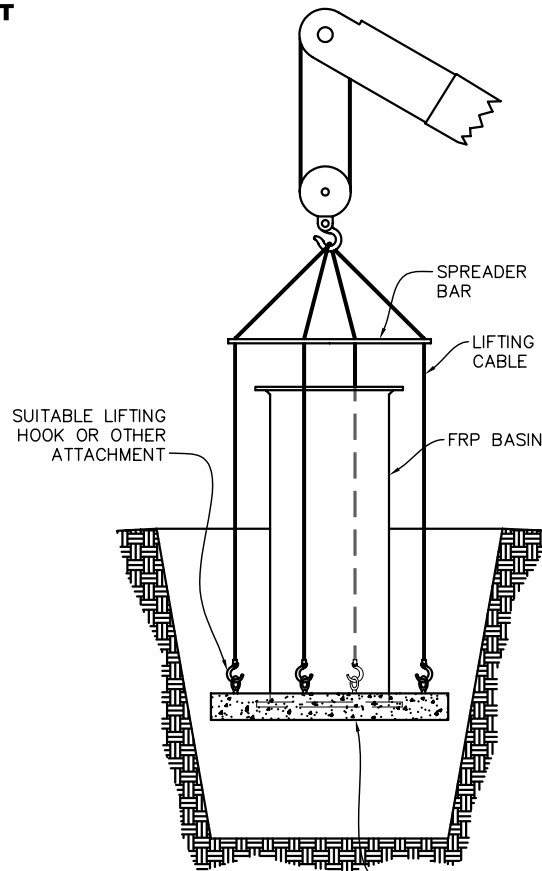
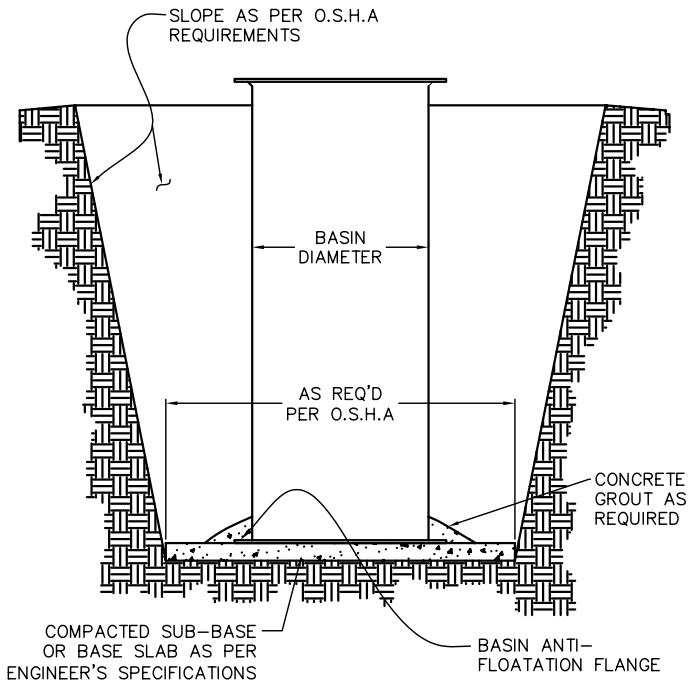

-INSTALLATION INSTRUCTIONS:

1. EXCAVATE HOLE TO THE REQUIRED SIZE.
2. INSTALL BASE, ENSURE THAT BASE IS LEVEL AND SMOOTH.
3. SET BASIN IN THE CENTER OF THE HOLE.
4. POUR CONCRETE GROUT AROUND ANTI-FLOATATION FLANGE AS REQUIRED.

-BACK FILL REQUIREMENTS:

1. BACK FILL IMMEDIATELY AFTER BASIN HAS BEEN SET IN PLACE.
2. PLACE BACK FILL MATERIAL IN 12" LIFTS AROUND THE BASIN AND COMPACT TO 700 SOIL MODULUS.

-INLET AND OUTLET INSTALLATION:

1. INSTALL INLETS AND OUTLETS AS REQUIRED WHEN BACKFILL IS WITHIN 2 ft. OF THAT ELEVATION.

THE INTENT OF THESE INSTALLATION INSTRUCTIONS IS TO ENSURE THAT DAMAGE TO THE BASIN OR WETWELL WILL NOT OCCUR. THESE INSTALLATION INSTRUCTIONS ARE NOT INTENDED TO PRECLUDE NORMAL SAFETY PROCEDURES WHICH SHOULD BE FOLLOWED TO PREVENT INJURY TO PERSONNEL. SAFE INSTALLATION PROCEDURES SHALL BE ENTIRELY THE RESPONSIBILITY OF THE INSTALLER.



STEELE PLASTICS, INC.
 P.O. Box 1076 / 1280 Sturgis Rd.
 Conway, AR 72033
 (501) 327-5122 Fax (501) 327-0807

TITLE RECOMMENDED BASIN INSTALLATION INSTRUCTIONS

PROJECT

JOB NO.

P.O. NO.

CUSTOMER

DWG. NO.

411-001