

BRASS

GATE VALVE

Features

- 200 PSI Non-shock WOG
- 125 PSI WSP Steam
- Full port
- Non-rising stem
- Cast iron handle
- Available in Handy Carton (HC) bin box packaging

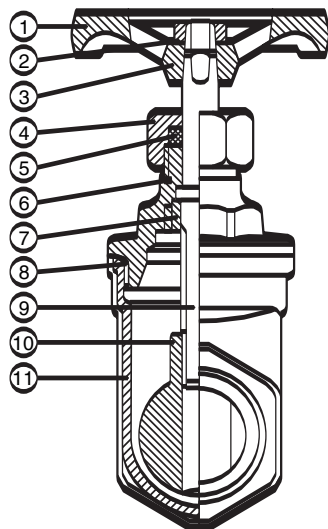
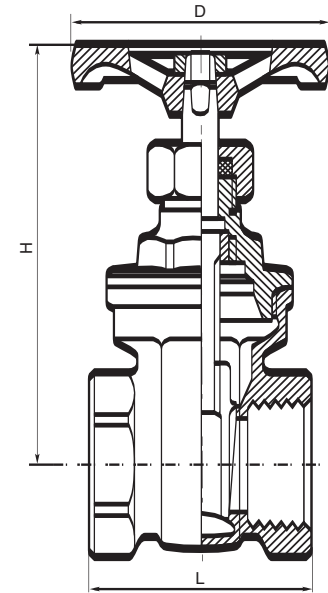

Materials & Specifications

No.	Desc	Material	
1	Wheel Nut	Steel	ASTM A563
2	Name Plate	Aluminum	
3	Handwheel	Cast Iron	ASTM A126B
4	Packing Nut	Brass Rod	ASTM B16
5	Gland Packing	Graphite Rubber	
6	Bonnet	Cast Brass	ASTM B16
7	Retainer	Brass Rod	ASTM B16
8	Washer	Teflon®	
9	Stem	Brass Rod	ASTM B16
10	Disc	Cast Brass	ASTM B16
11	Body	Cast Brass	ASTM B16

Dimensions are in Inches

Part No.	Size	D	H	L	d	(NPT)
100-001	1/4	2.07	2.72	1.57	0.43	(18)
100-002	3/8	2.07	2.83	1.61	0.45	(18)
100-003	1/2	2.07	2.99	1.71	0.49	(14)
100-004	3/4	2.07	3.31	1.81	0.75	(14)
100-005	1	2.32	3.74	2.09	0.98	(11.5)
100-006	1-1/4	2.64	4.53	2.32	1.22	(11.5)
100-007	1-1/2	2.95	5.12	2.44	1.50	(11.5)
100-008	2	3.62	5.91	2.80	1.89	(11.5)
100-009	2-1/2	4.33	7.80	3.85	2.48	(8)
100-010	3	4.61	8.90	3.82	2.83	(8)
100-011	4	4.92	10.39	4.53	3.66	(8)

Working Pressure

Working Pressure Non-Shock (psi)		Test Pressure (psi)	
Saturated Steam	Cold Water, Oil, Gas	Shell (Air)	Seat (Air)
125	200	80	80

Weight (in ounces)

Size	1/4	3/8	1/2	3/4	1	1-1/4	1-1/2	2	2-1/2	3	4
Ounce	9.44	8.96	9.76	12.96	18.24	26.40	34.56	52.00	96.00	143.36	224.00



B&K Part No.
100-001 to 100-011
 1/4" to 4"
 Threaded

- Meets NSF 61-8 approved low lead standards
- Threaded ends comply with ANSI B1.20.1
- Solder ends comply with ANSI B16.18



Leadership By Design®

Mueller/B&K Industries, Inc. • 2600 Elmhurst Road • Elk Grove Village, IL 60007
 (847) 773-8585 • (800) 782-2385 • FAX (847) 773-0330 • www.bk-ind.com

©2006 Mueller/B&K Industries, Inc.

LIT-640